

V1
ESC 1:50

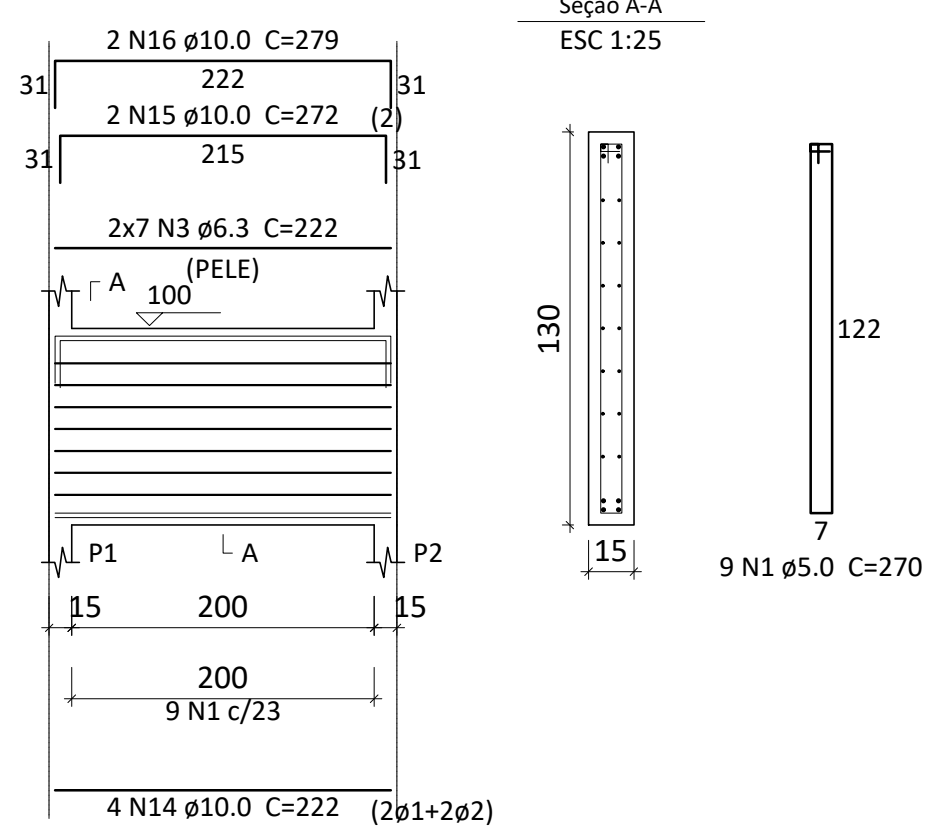

V2
ESC 1:50

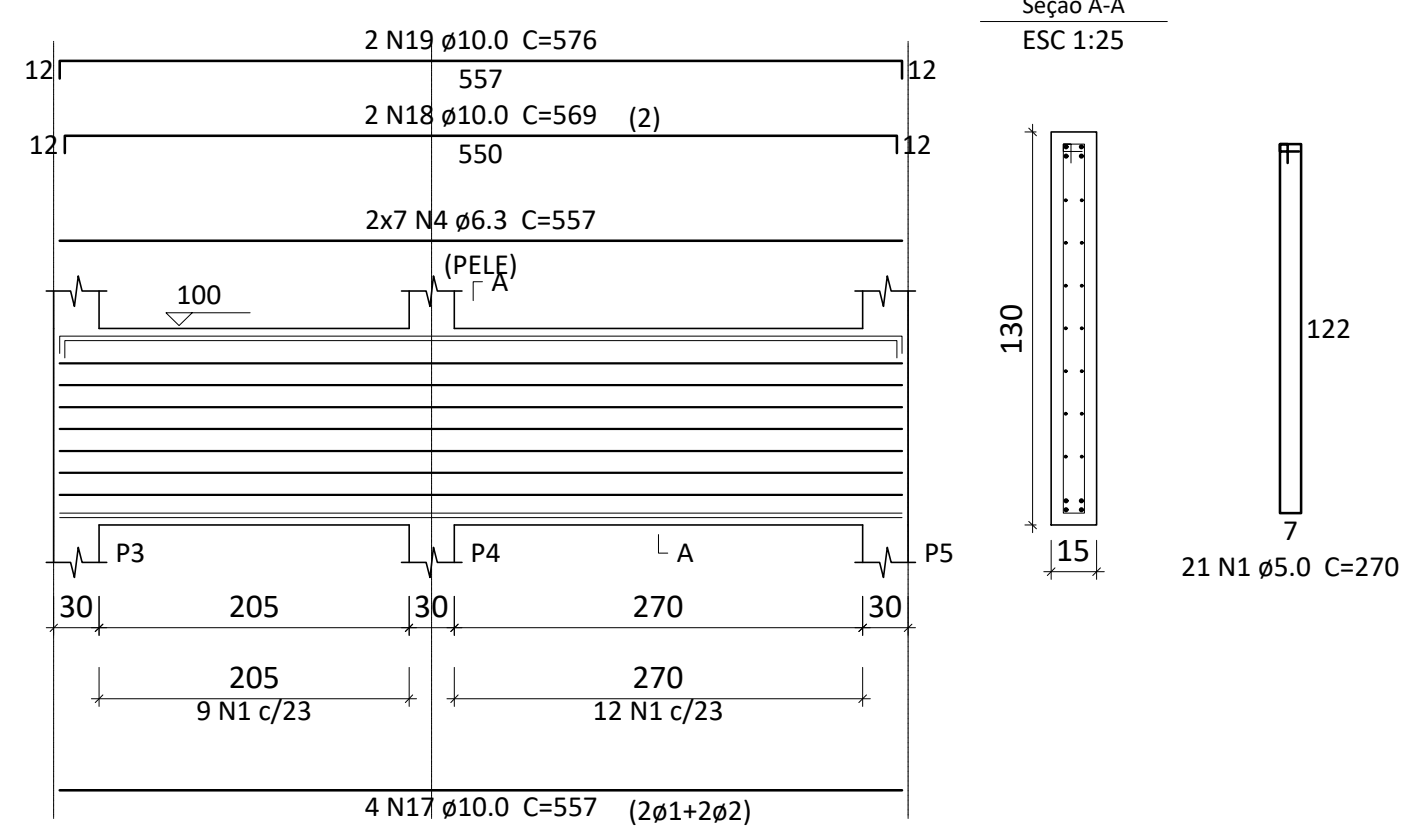

V3
ESC 1:50

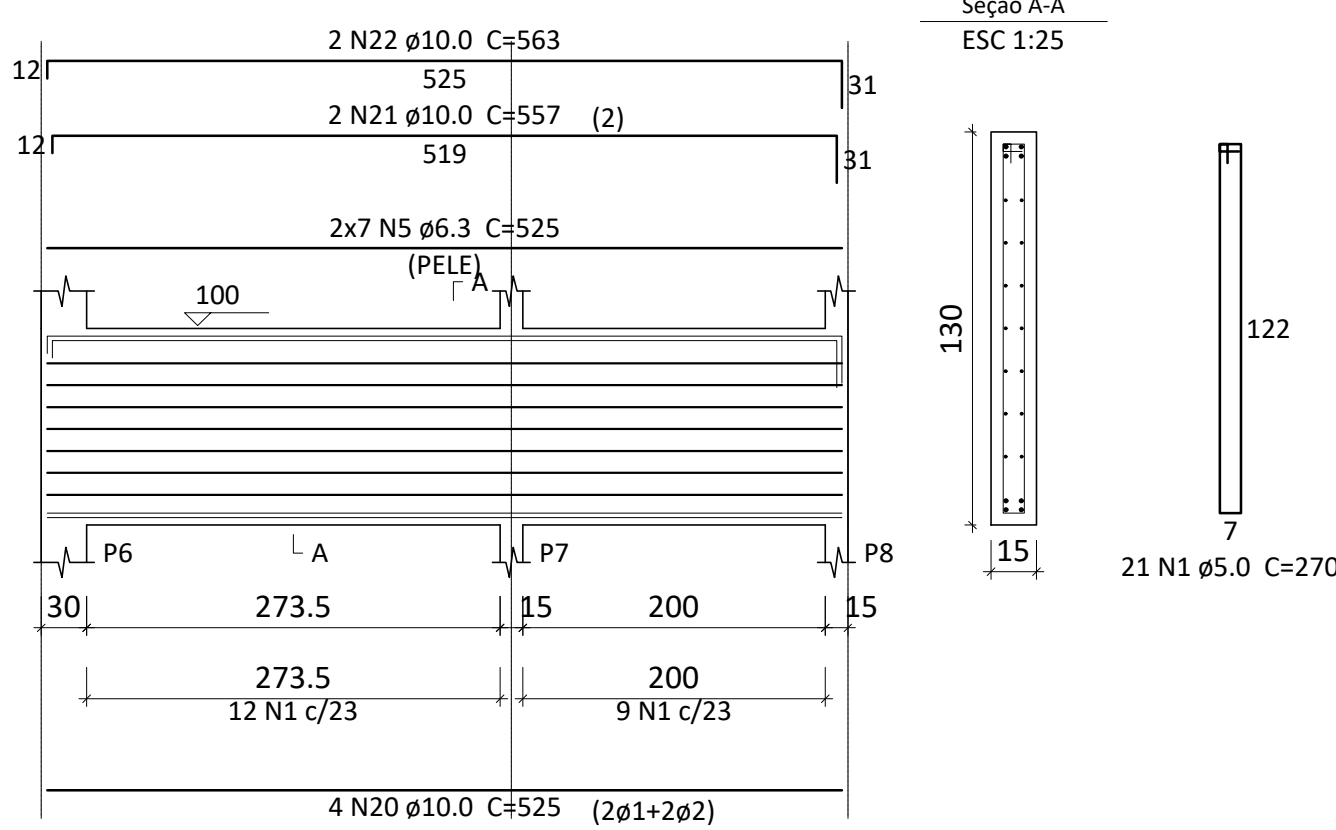

V4
ESC 1:50

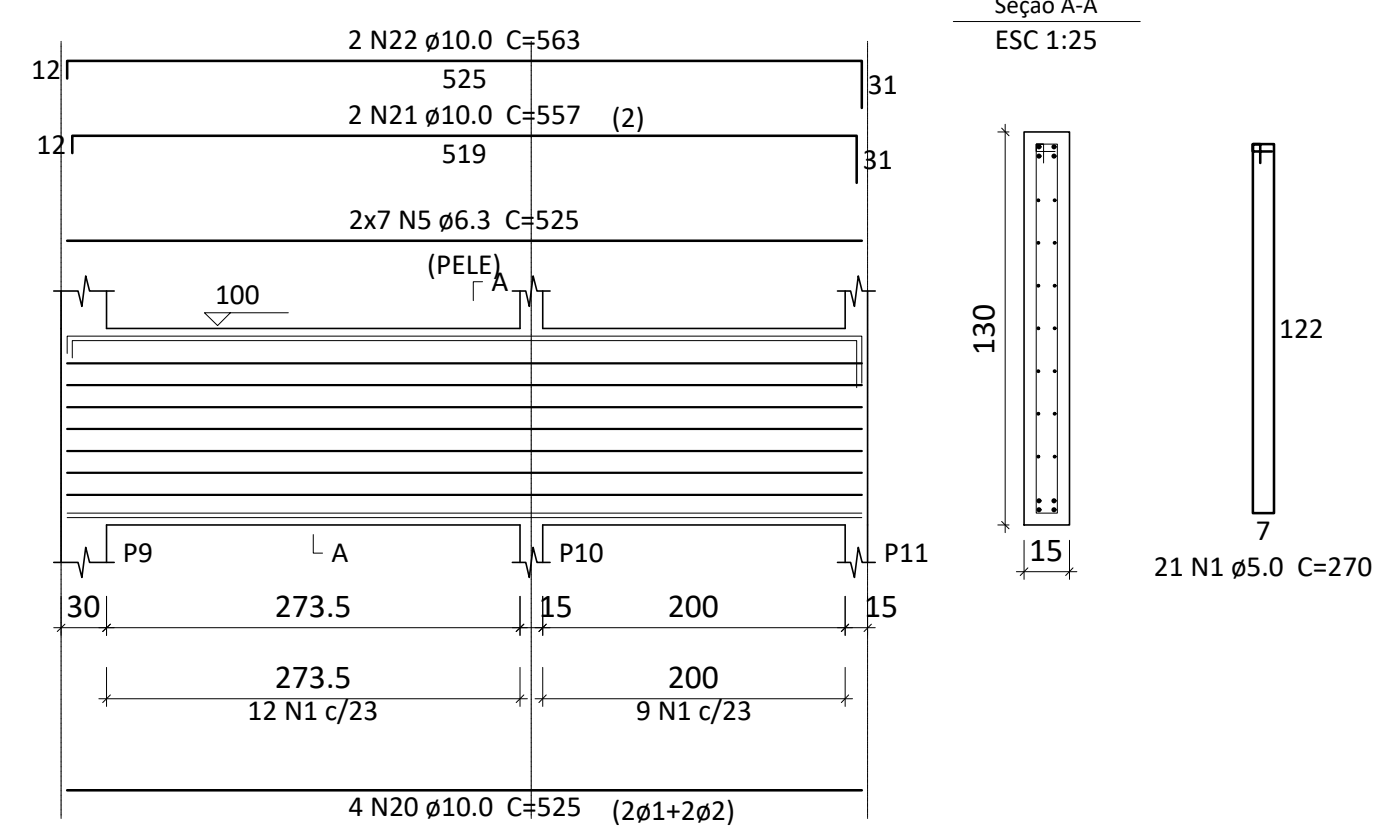

V5
ESC 1:50

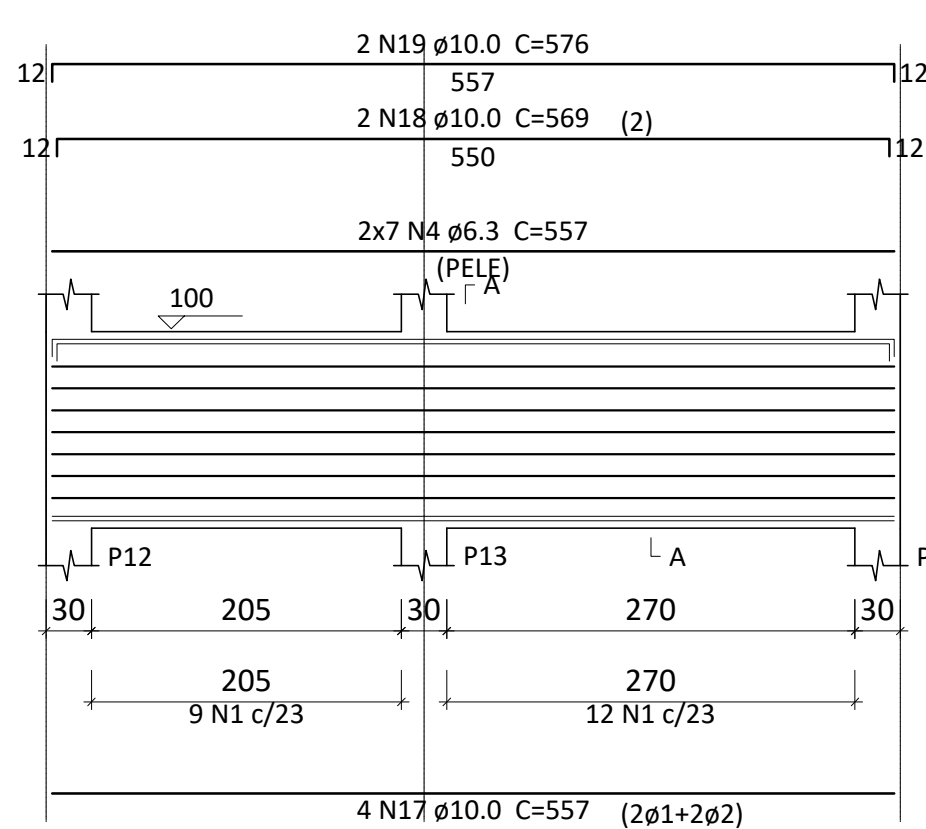

V6
ESC 1:50

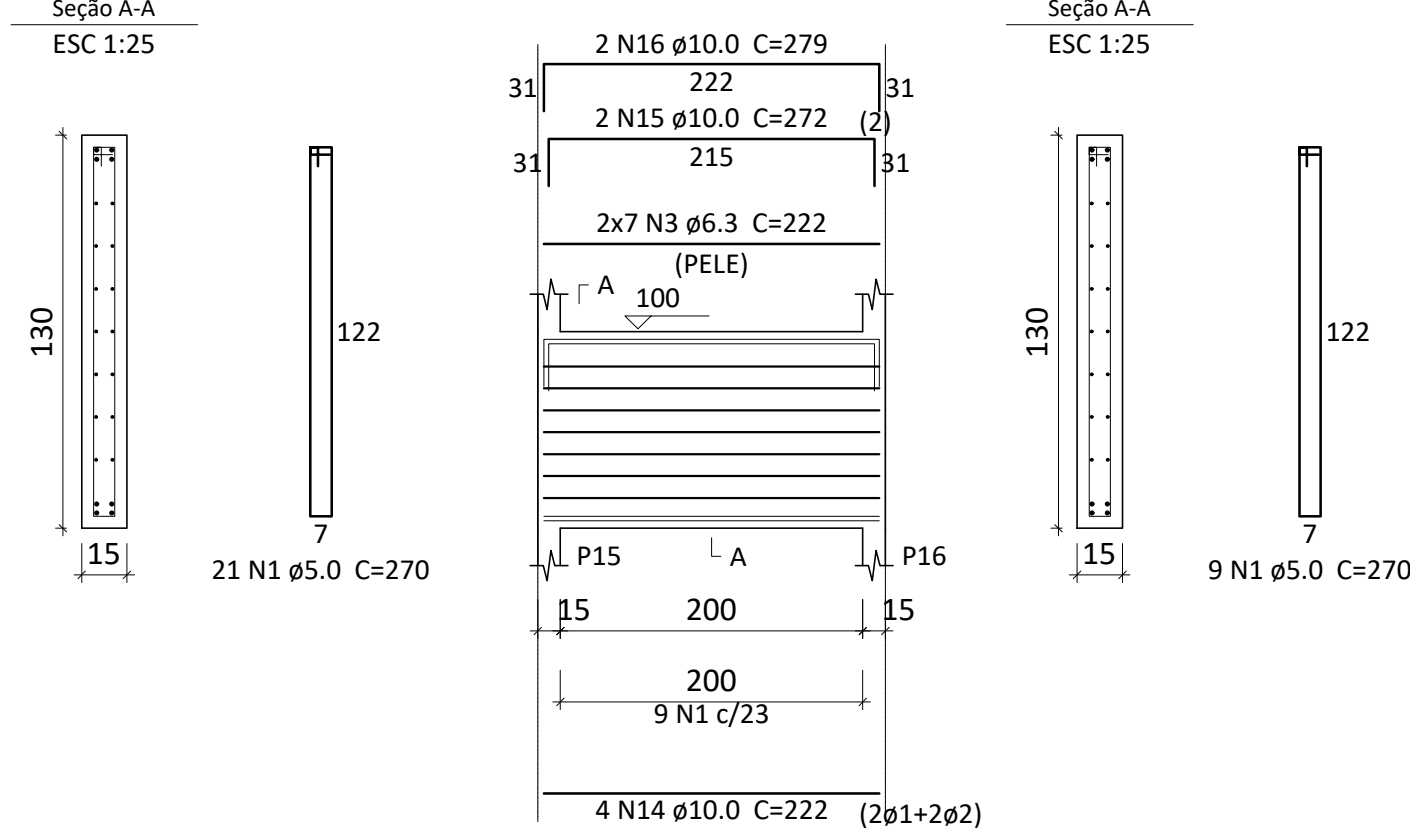

V7
ESC 1:50

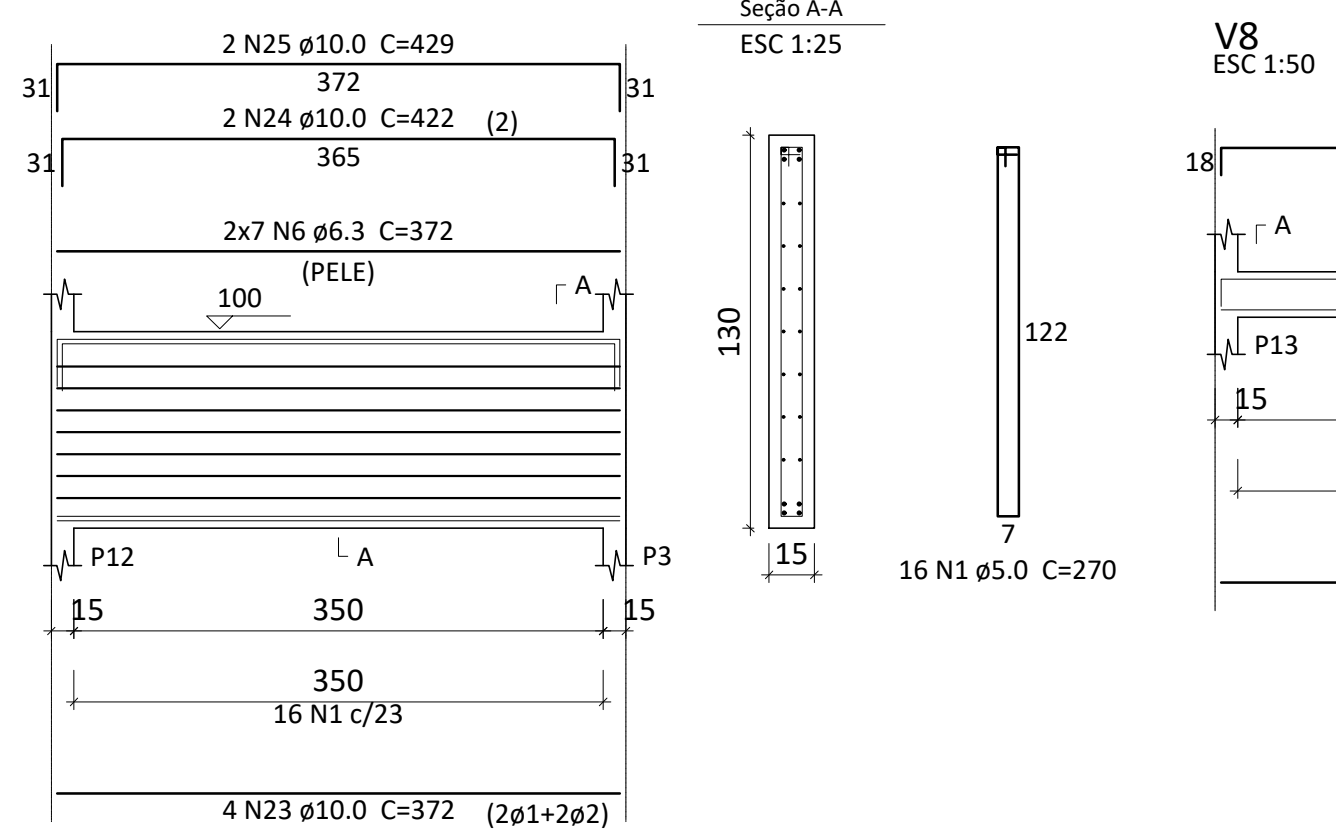

V8
ESC 1:50

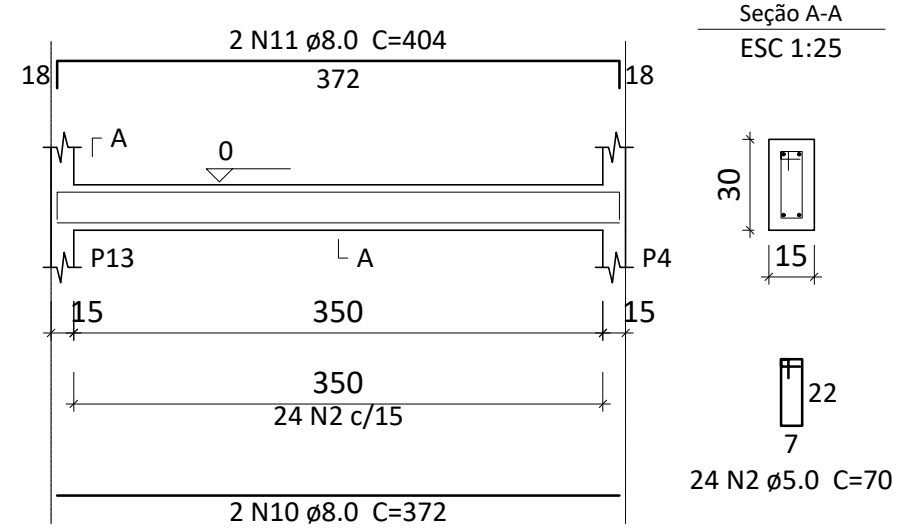

V9
ESC 1:50

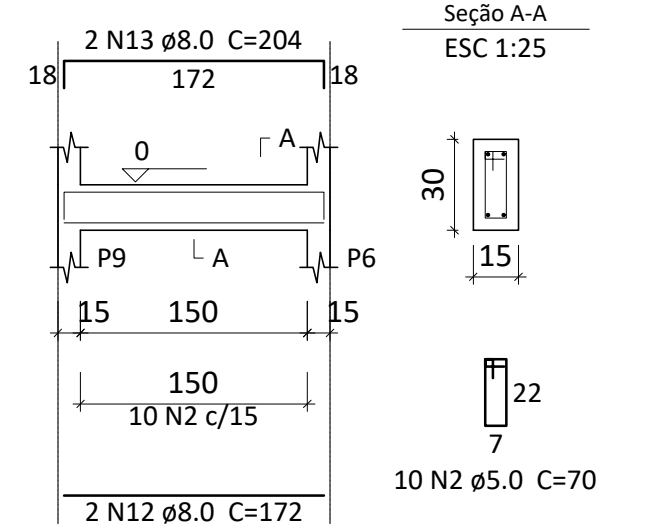

V10
ESC 1:50

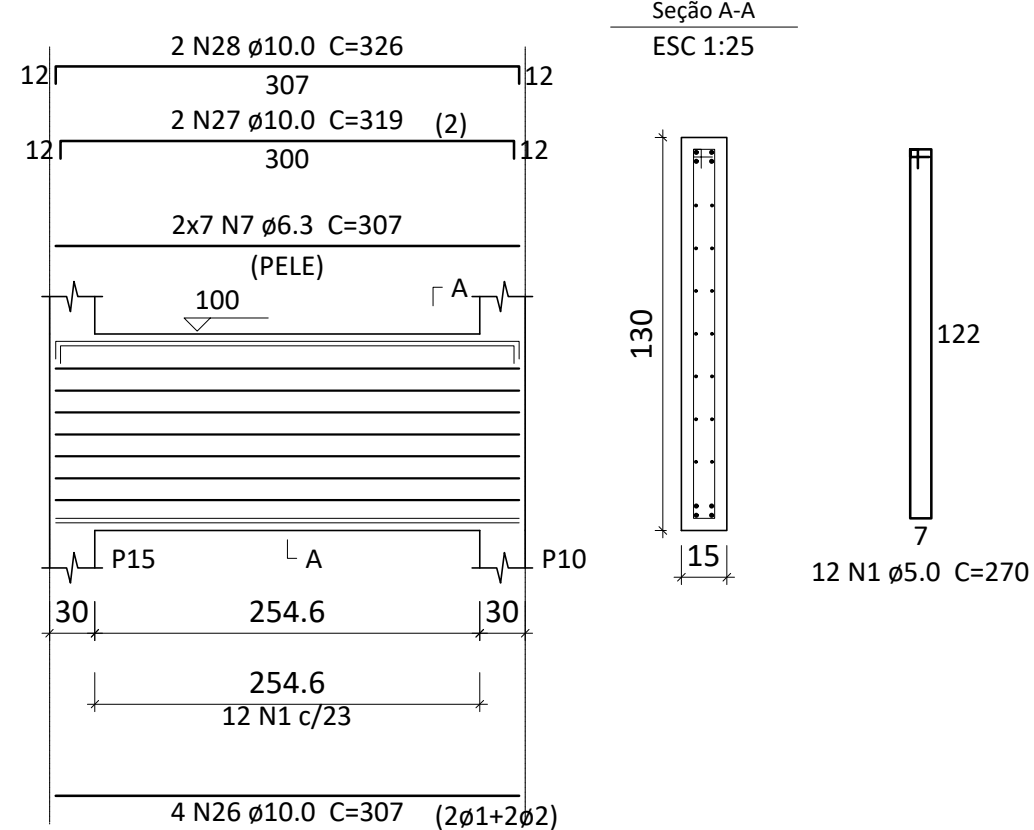

V11
ESC 1:50

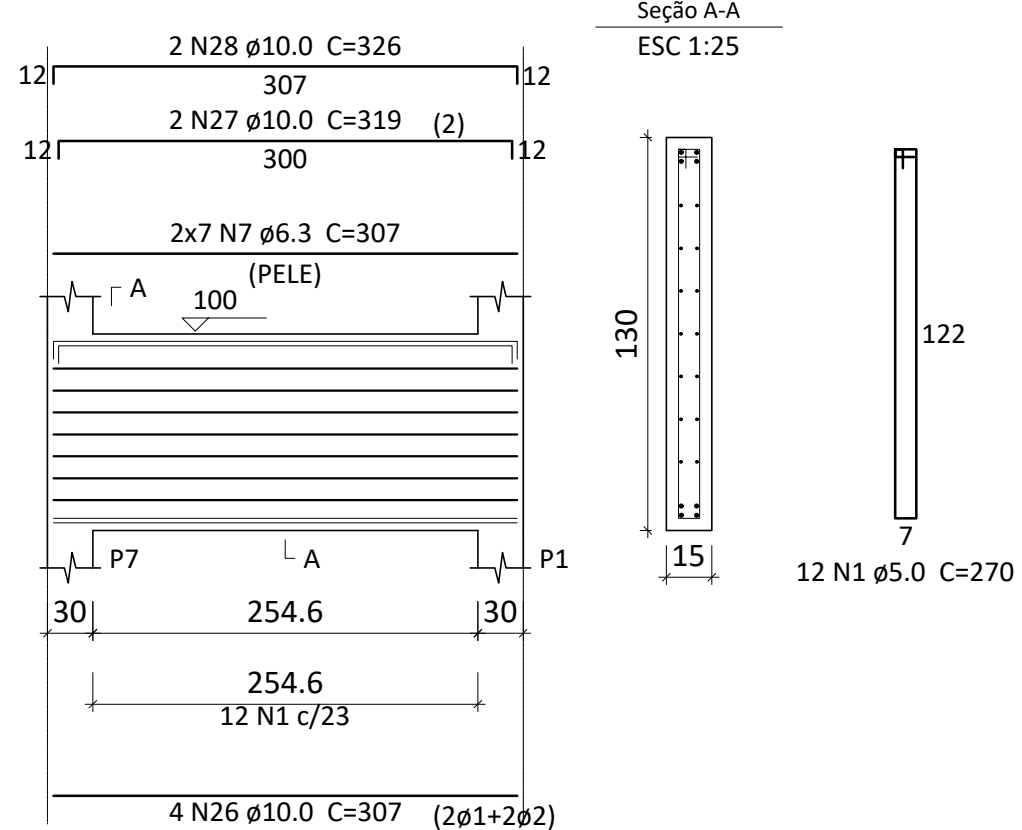

V12
ESC 1:50

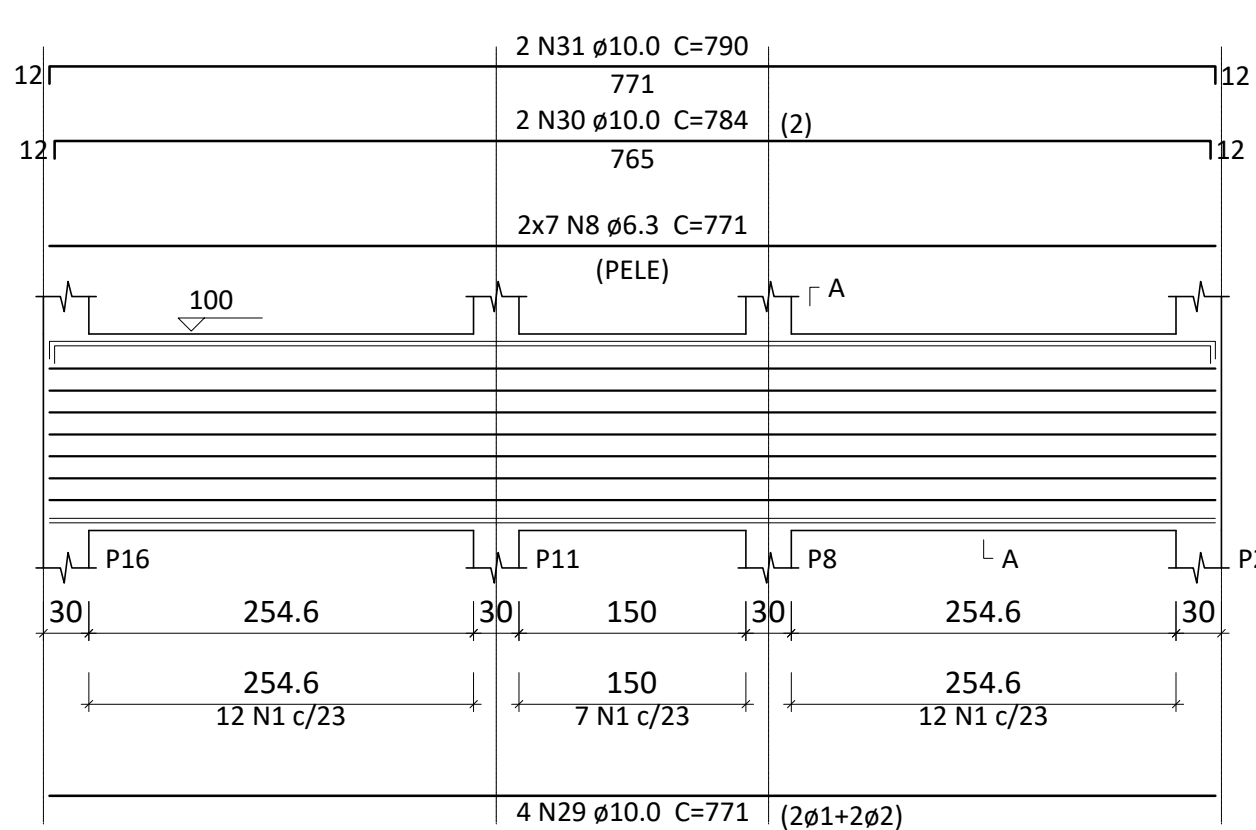

V13
ESC 1:50

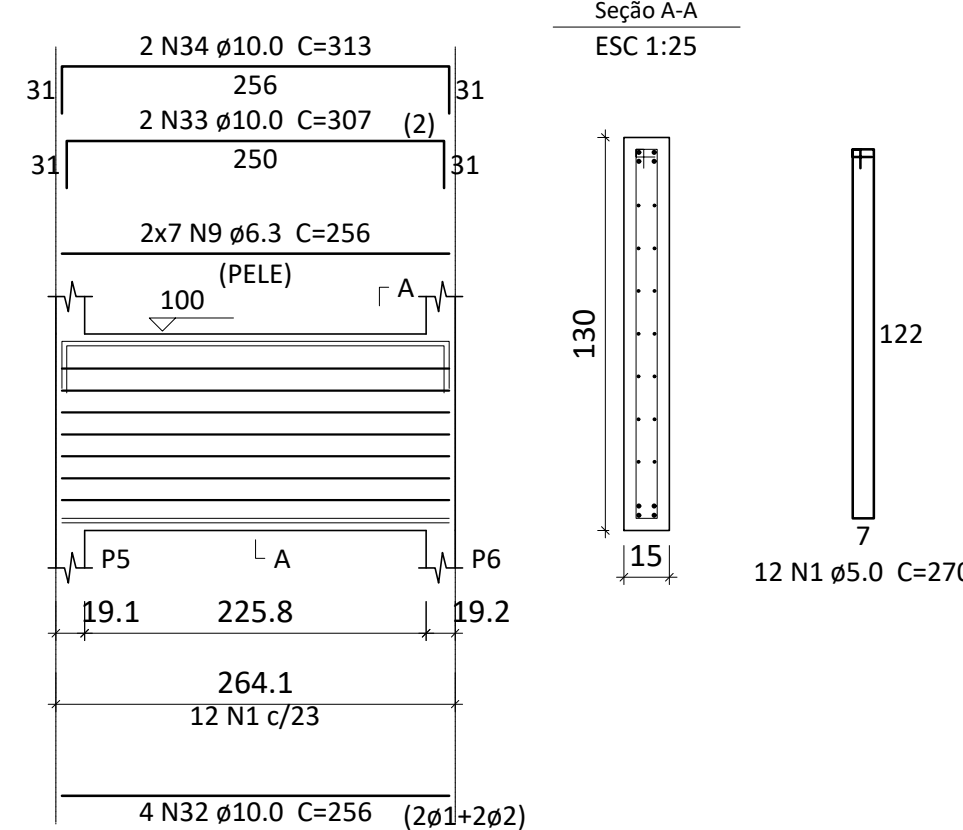

V14
ESC 1:50

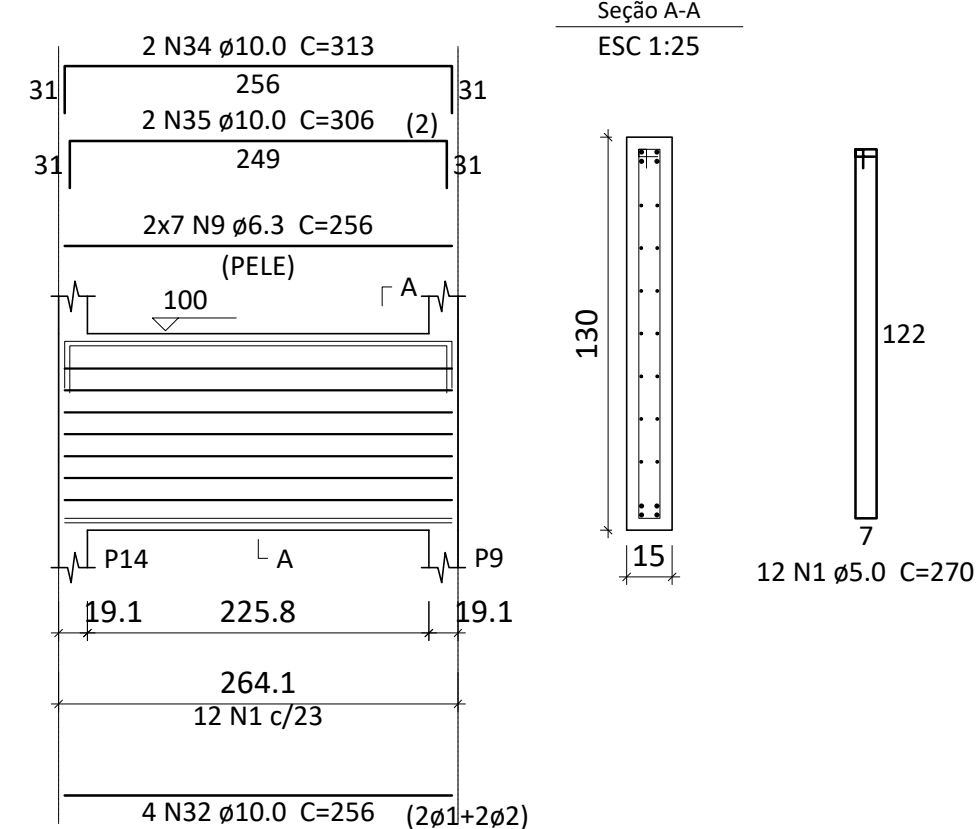

Relação do aço

AÇO	N	DIAM	Q	UNIT (cm)	C.TOTAL (cm)
CA60	1	5.0	197	270	53190
	2	5.0	34	70	2380
CA50	3	6.3	28	222	6216
	4	6.3	28	557	15596
	5	6.3	28	525	14700
	6	6.3	14	372	5208
	7	6.3	28	307	8596
	8	6.3	14	771	10794
	9	6.3	28	256	7168
	10	8.0	2	372	744
	11	8.0	2	404	808
	12	8.0	2	172	344
	13	8.0	2	204	408
	14	10.0	8	222	1776
	15	10.0	4	272	1088
	16	10.0	4	279	1116
	17	10.0	8	557	4456
	18	10.0	4	569	2276
	19	10.0	4	576	2304
	20	10.0	8	525	4200
	21	10.0	4	557	2228
	22	10.0	4	563	2252
	23	10.0	4	372	1488
	24	10.0	2	422	844
	25	10.0	2	429	858
	26	10.0	8	307	2456
	27	10.0	4	319	1276
	28	10.0	4	326	1304
	29	10.0	4	771	3084
	30	10.0	2	784	1568
	31	10.0	2	790	1580
	32	10.0	8	256	2048
	33	10.0	2	307	614
	34	10.0	4	313	1252
	35	10.0	2	306	612

Resumo do aço

AÇO	DIAM	C.TOTAL (m)	PESO + 10% (kg)
CA50	6.3	682.8	183.8
	8.0	23.1	10
	10.0	406.8	275.9
CA60	5.0	555.7	94.2

Vol. de concreto total (C-25) = 9.95 m³
Área de forma total = 140.97 m²

ESTRUTURAL

CENTRO DE TREINAMENTO



RENATO MEDEIROS SPERB
ENGENHEIRO CIVIL CREA 042680-9

RUA PASTOR BLUMEL Nº 30 - SALA 01
CENTRO - TIMBÓ - SC

(47) 99981 4941

renatomsp@br@gmail.com@gmail.com

Rua: Rua Itapema, nº 310 - Bairro Quintino
Timbó - SC

Data: novembro/2019 Escala: Indicada

Responsável Técnico: ART nº:

Área: Desenho: Renato

CORPO DE BOMBEIROS MILITAR - TIMBÓ - SC

ESPECIFICAÇÃO:

VIGAS PAREDE 1

PRANCHA

EST 06